

# Alkaline Water Electrolyzer Stack Install Guide (LSCF5)

## User Manual



科学材料站  
SCI Materials Hub

*Tel: +86 13003038751*  
*Fax: +86 553-7458-388*  
*Email: [contact@scimaterials.cn](mailto:contact@scimaterials.cn)*  
*[www.scimaterials.cn](http://www.scimaterials.cn)*

# Contents

|                         |    |
|-------------------------|----|
| 1. Stack Specification  | p3 |
| 2. Connection Method    | p4 |
| 3. System Schematics    | p5 |
| 4. Operation Conditions | p6 |
| 5. Cautions             | p7 |

# 1. Stack Specification



- Model name: LSCF 5
- Size: 100 X 100 X 51mm
- Material: FRP, Engineering plastic
- Number of unit cell: 5 ea
- Separation membrane: Porous polymer
- Electrode material: Nickel based compound
- Current density: 300~500mA/cm<sup>2</sup> @ 1.8V
- Power capacity range: 12.5W ~ 100W
- Electrolyte: Alkaline solution(KOH, 30w%)

## 2. Connection Method

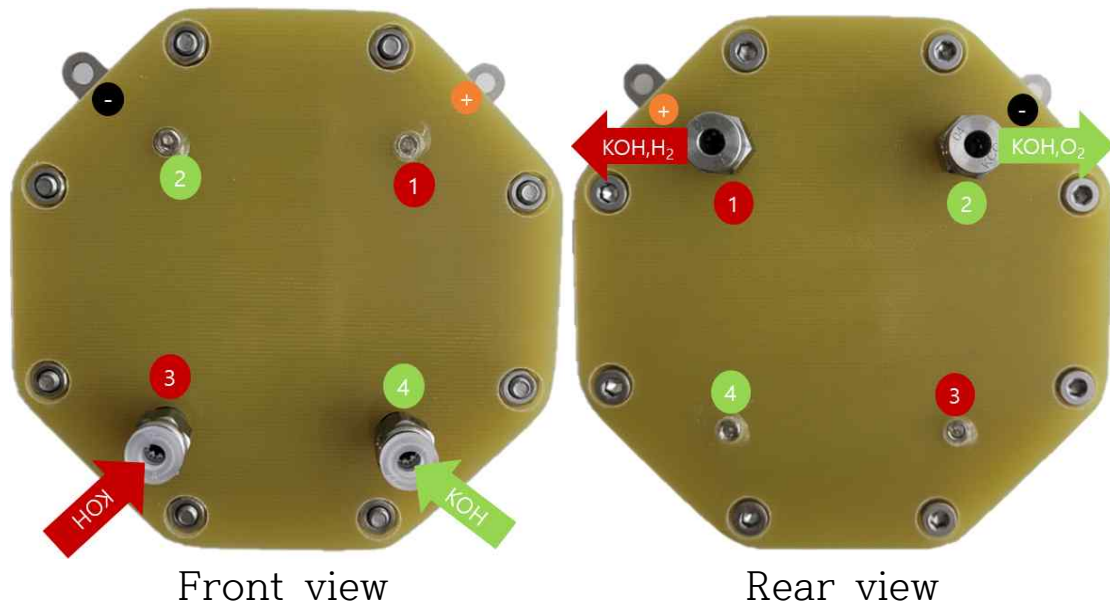

- ① Block Port 1, Port 2 in the front view of the stack.
- ② Block Port 3 and Port 4 in the rear view of the stack.
- ③ Insert electrolyte liquid into Port 3 and Port 4 in the front view of the stack.
- ④ Connect Port 1 in the rear view of the stack to the separator from the hydrogen side.
- ⑤ Connect Port 2 in the rear view of the stack to the separator from the oxygen side.
- ⑥ For the detailed connections, Please refer to the system schematics.

### 3. System schematics

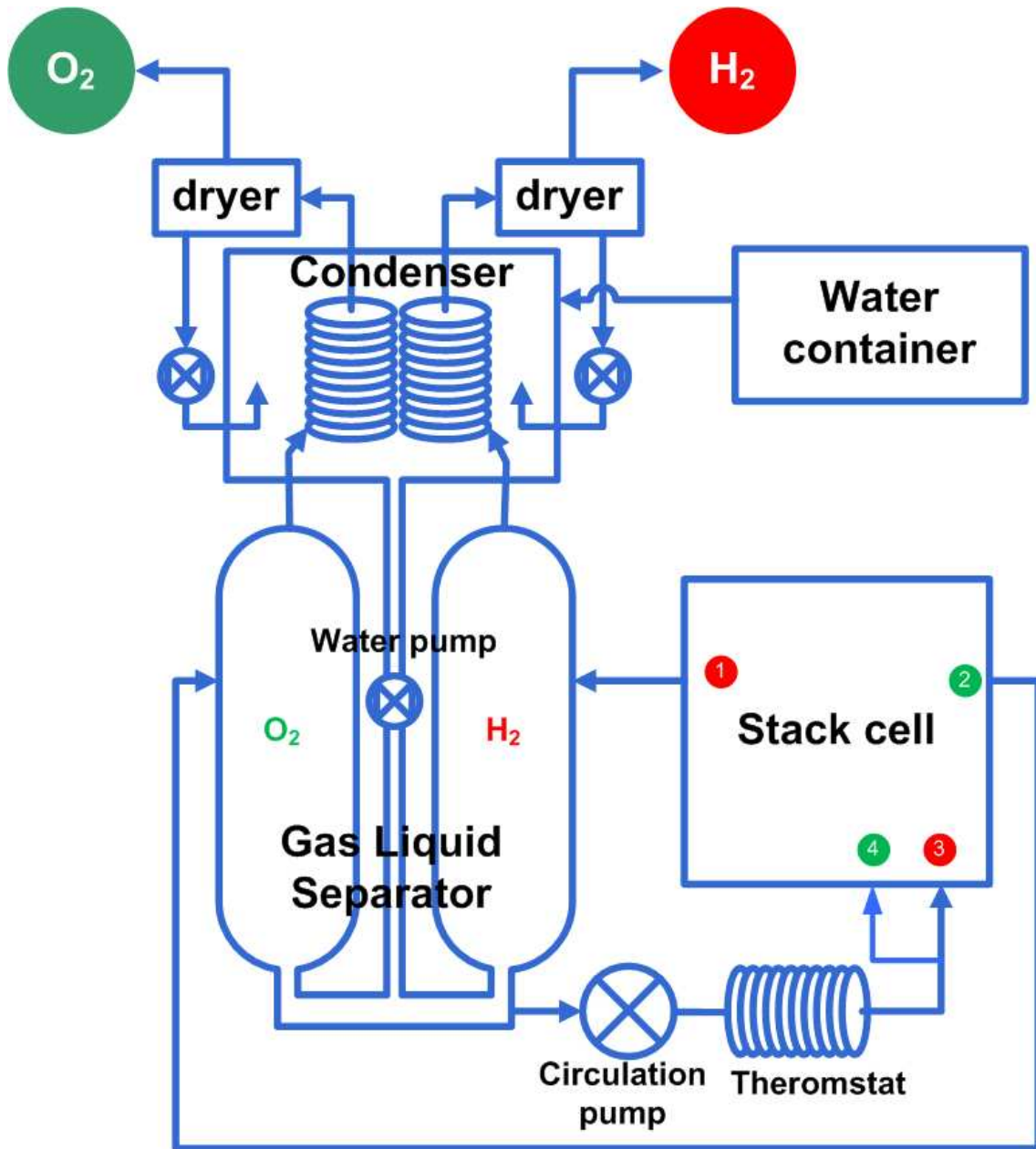

## 4. Operation Conditions

- ① Please set the basic BOP system of the alkaline electrolyzer before the start.
- ② KOH has the best performance in 30w% of concentration, and shows the highest performance when the temperature is 80°C.
- ③ Connect the + label electrode to the positive voltage and the – label electrode to the negative voltage.
- ④ Apply the voltage of 7.5V ~ 10V.
- ⑤ During the start of electrolysis, it needs sufficient aging. Try to let the temperature rise due to the electric power from the electrolysis, and it is recommended to install the cooling system.
- ⑥ Operation condition has to be adequately adjusted according to the function of temperature and current.
- ⑦ The circulation speed of the electrolyte has to be maintained at 50cc/min.(Gear pump is recommended)

## 4. Cautions

- Make sure electrolyte solution (KOH) does not contact with the skin.
- Do not lay the electrolyzer stack by side of upside down.
- Do not disassemble or open the stack.
- Do not raise the pressure of hydrogen and oxygen production above 3bar
- Do not allow the setting of the heater temperature to be above 80°C.
- If the electrolyte solution leaks, stop the operation and ask for customer support.
- Do not arbitrarily short the electrodes of the stack.
- Please try to apply DC power or pulse form power to the stack.
- Please try not to apply the voltage over 10V.

**\*Note: No refunds and warranties will be given once the product is disassembled.**



科学材料站  
SCI Materials Hub

Tel: +86 13003038751  
Fax: +86 553-7458-388  
Email: [contact@scimaterials.cn](mailto:contact@scimaterials.cn)  
[www.scimaterials.cn](http://www.scimaterials.cn)